

The general goal of this lab is to review basic circuit theory and review operation of test equipment that will be used in lab this quarter including voltmeters, oscilloscope, signal generator, power supply, and the WWU bread boards.

Objectives:

- Review operation and use of basic electronic test equipment
- Observe and quantify loading effects
- Understand methods and limitations of AC measurements

Note that when recording voltage measurements you must state the units and type of voltage and use the number of significant digits appropriate to the accuracy of the measurement. For DC (direct current) use xx.xx V DC. For AC (alternating current), use xx.xx V_{pp} for peak-to-peak voltage, V_{peak} for zero-to-peak voltage, or V_{rms} for RMS voltage.

Equipment provided:

- HP 6236B DC Power supply
- Fluke 8846A Benchtop Digital Multi-Meter (DMM)
- Wavetek 220 handheld DMM
- Tektronix TBS2000 Series Oscilloscope
- Agilent 33250A Function generator
- Decade resistance box
- Breadboard
- Assorted resistors

Procedure:

Part 1: DC measurements

Construct the voltage divider circuit shown below on a breadboard, but measure each resistor before placing it in the circuit. Use a Fluke 8846A meter to measure resistance and also to set the power supply to 5.00 V DC as closely as possible.

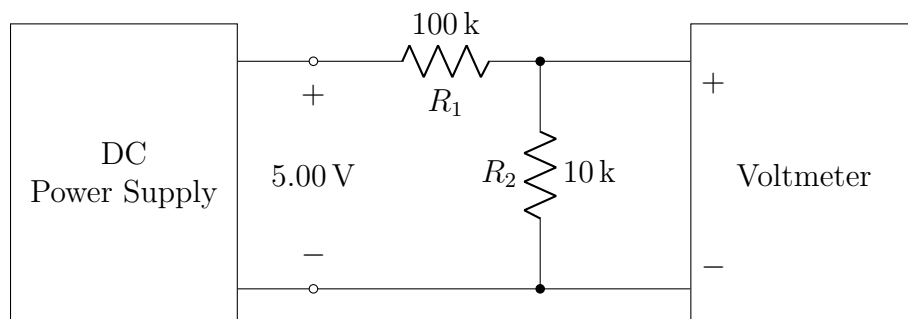

1. Calculate the percentage error for each resistor from its nominal value as

$$100\% \times \frac{\text{measured value} - \text{nominal value}}{\text{nominal value}}.$$

In your report, provide a table showing the nominal and measured values and the percentage error for each resistor. (Resistors like these are commonly specified with a *tolerance* of 5%.)

2. Use circuit theory and the measured resistances to calculate the theoretical voltage across R_2 (i.e. use the voltage divider relationship). Then, measure the DC voltage across R_2 with a Fluke 8846A meter, and compare this with the theoretical value.

Do you expect a significant loading effect from the input resistance of the meter? Explain why, or why not, supporting your answer with a simple calculation. (See the Fluke 8846A specifications here—the default input resistance is 10 M Ω .)

3. Measure the current flowing from the power supply through this circuit. (Recall that to measure current the meter must be placed **in series** with the circuit.)

Part 2: AC sinusoidal voltage measurement

Set up the Agilent function generator as shown below with the necessary adapter(s) to connect its output to the voltmeters or the oscilloscope. Set the signal generator wave-type to a sine wave with 2.0 volts peak-to-peak amplitude (2.0 V_{pp}) as reported on the display of the signal generator. Set the offset voltage to zero and the frequency to 100 Hz. Be sure to indicate units and the type of voltage being measured i.e. rms, peak, etc.

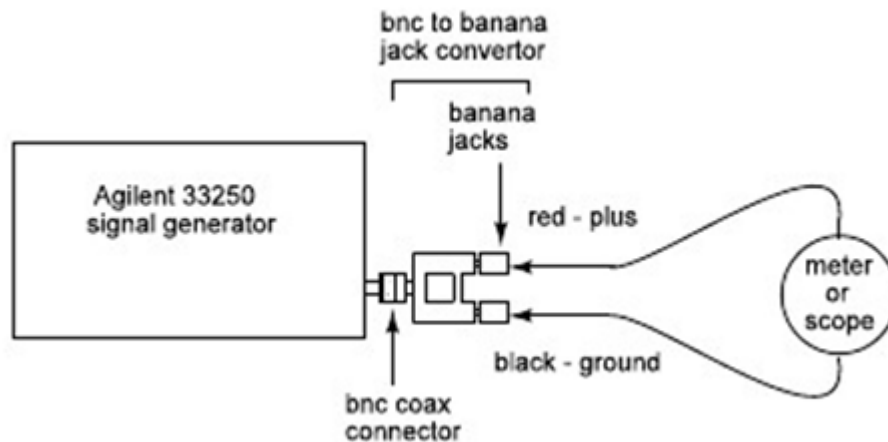

4. Measure the AC voltage with the Fluke 8846A, then repeat using the Wavetek 220 handheld meter. Using this single data point, treat the 8846A as a calibration standard—that is, assume that the 8846A reading is correct—and determine a calibration factor for the handheld meter. Multiplying the Wavetek reading by this calibration factor should give the value measured with the Fluke. (The readings should be relatively close so your calibration factor will be close to one.)
5. Measure V_{pp} with the oscilloscope by visually measuring the displayed waveform using the grid scale on the scope face. (Do not use the digital readout features yet.)

6. Now use the oscilloscope's "Measure" function to measure both V_{pp} and V_{rms} .

Part 3: Non-sinusoidal voltage measurement

Use the same setup as in Part 2 above but change the signal generator waveform to a square wave. Continue using $2.0 V_{pp}$ amplitude with zero offset and a frequency of 100 Hz.

7. Calculate by hand the RMS amplitude of this waveform. Here is the formula in case you forgot it:

$$\sqrt{\frac{1}{T} \int_0^t (f(t))^2 dt}$$

8. Measure the AC voltage with the 8846A meter, then with the handheld meter. Repeat the procedure in step 4 by again measuring the AC voltage with the 8846A meter and the handheld meter, then determining a calibration factor for the handheld meter.
9. Are the calibration factors the same for steps 4 and 8? What are your thoughts on the methods used by both meters to measure AC voltage?
10. Add a 2.0 V DC offset by selecting it on the signal generator menu. Calculate by hand the new, expected RMS voltage.
11. Measure the voltage again with both meters (benchtop and handheld) and the oscilloscope (using its measure function). What do you observe?

Part 4: Waveform measurements

Use the same equipment and hook-up as in Part 3, but change the frequency to 10 kHz. Continue using $2.0 V_{pp}$ amplitude with zero offset.

12. Visually measure the waveform period with the oscilloscope (using grid lines, not the measure function).
13. Visually measure waveform rise time and fall time with the oscilloscope. Sketch the edge shapes and annotate with measured values. Ask the instructor or lab TA for help if needed.

Part 5: Instrument imperfections

Multimeters are used to make current, voltage, and resistance measurements in both AC and DC circuits. We would like to avoid if at all possible a situation where the instrument itself affects the circuit under measurement. In this part of the laboratory experiment, we will use two meters to make measurements in two different ways, and then compare the results.

Resistance can be determined by measuring voltage and current and then calculating R from Ohm's Law. There are two possible circuit arrangements for measuring V and I as shown below:

Of course, it is desired to measure the voltage across the resistor while simultaneously measuring the current through it. However, a careful look at the circuits shows that there is a measurement flaw in each of them: In Circuit 1, the voltmeter measures the voltage across the ammeter and the resistor in series, while in Circuit 2, the ammeter measures the sum of the currents passing through the resistor and the voltmeter. If the meters were ideal, no current would pass through the voltmeter and no voltage drop would appear across the ammeter.

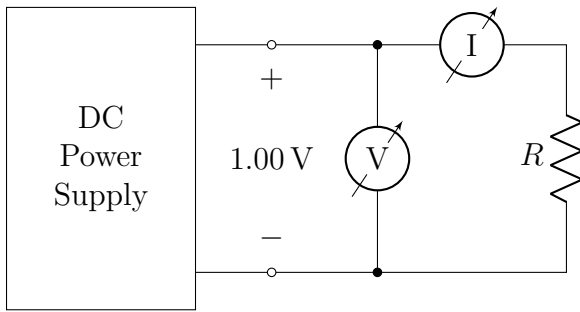

Circuit 1

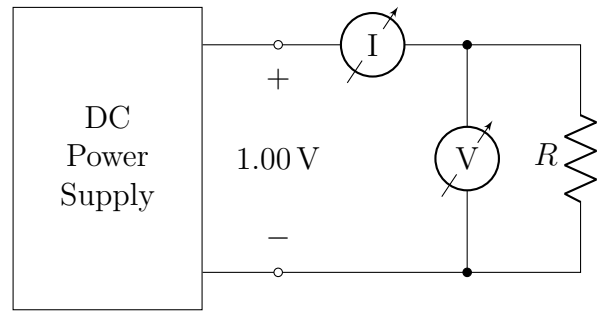

Circuit 2

14. Connect circuit 1 above. A breadboard is not necessary. Set the DC input voltage as close to 1.00 V as possible. Using the decade resistance box, measure and record V , I , and R for R ranging from $50\ \Omega$ to $100\ \Omega$ in $10\ \Omega$ steps. In your report, include a table with the measured V , I , dial resistance R_{dial} , and calculated resistance R_{calc} .

Note 1: Be absolutely sure that you do not put power to your circuit when the decade resistance box is set to $0\ \Omega$.

Note 2: Use the Fluke 8846A meter to measure current and the handheld meter to measure voltage.

15. Implement circuit 2 above and repeat the previous step, creating a second data table.
16. Using Matlab or Excel, on the same graph plot the calculated R_{calc} values on the y-axis versus R_{dial} on the x-axis for both circuits. Be sure to label which is circuit 1 and which is circuit 2. Use a least-squares linear fit (see Lab #1) to draw one straight line fitting the data from circuit 1, and another straight line fitting the data from circuit 2. The second line should parallel the first line.

Note: Be sure to follow the School of Engineering's graphing guidelines published on the course D2L site.

17. Discuss why the calculated values of R from circuit 2 are equal to the values of R set on the decade box dial, while the values of R calculated from circuit 1 are not. Note the constant difference between the two lines in the graph and relate this to the input resistance of the meter.