

FEDERAL[®]

μMaxμm[®]

Users Manual

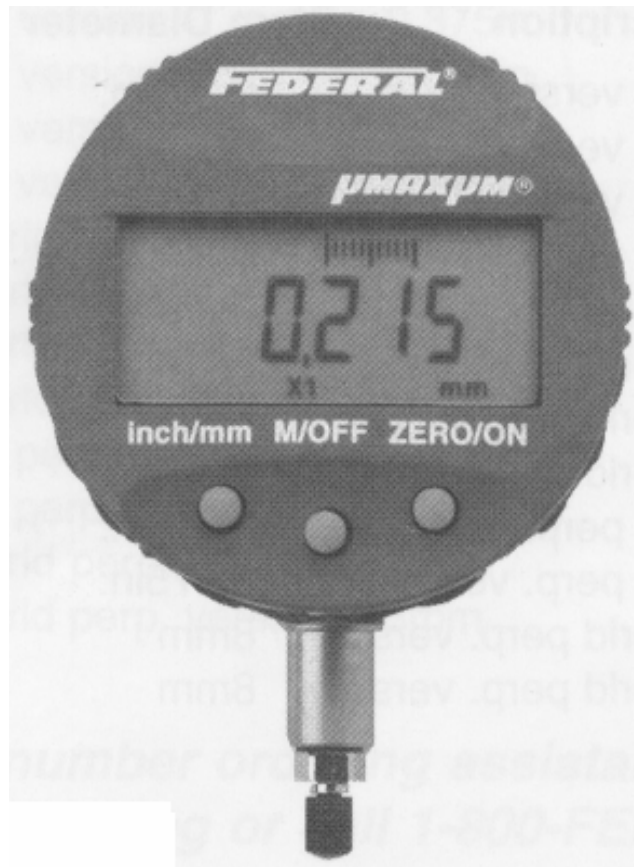

μMaxμm® Models

These instructions cover the following μMaxμm® Digital Indicators:

STANDARD RESOLUTION MODELS:

Part	Description	Stem Diameter	Stem Length
EDI-10101	US version	0.375in.	0.46in.
EDI-10102	US version	0.375in.	0.46in.
EDI-10201	US version	0.375in.	1.5in.
EDI-10202	US version	0.375in.	1.5in.
EDI-10301	World version	8mm	11.68mm
EDI-10302	World version	8mm	11.68mm
EDI-10401	World version	8mm	38.1 mm
EDI-10402	World version	8mm	38.1 mm
EDI-30100	US perp. version	0.375in.	0.46in.
EDI-30200	US perp. version	0.375in.	1.5in
EDI-30300	World perp. version	8mm	11.68mm
EDI-30400	World perp. version	8mm	38.1 mm

HIGH RESOLUTION MODELS:

Part	Description	Stem Diameter	Stem Length
EDI-20101	US version	0.375in.	0.46in.
EDI-20102	US version	0.375in.	0.46in.
EDI-20201	US version	0.375in.	1.5in.
EDI-20202	US version	0.375in.	1.5in.
EDI-20301	World version	8mm	11.68mm
EDI-20302	World version	8mm	11.68mm
EDI-20401	World version	8mm	38.1 mm
EDI-20402	World version	8mm	38.1 mm
EDI-40100	US perp. version	0.375in.	0.46in.
EDI-40200	US perp. version	0.375in.	1.5in.
EDI-40300	World perp.version	8mm	11.68mm
EDI-40400	World perp. version	8mm	38.1 mm

For model number ordering assistance see the product catalog or call 1-800-FEDGAGE.

CONTENTS

- 1.0 Precautions and General Information
- 2.0 Product Features
- 3.0 Inspection
- 4.0 Mounting the Gage for Setup
- 5.0 Setup Modes
 - 5.1 Changing Measurement Direction
 - 5.2 Changing Analog Magnification
 - 5.3 Entering Preset
 - 5.4 Entering Tolerances
 - 5.5 GO/NOGO operation
 - 5.6 Calibration Mode
- 6.0 Operational Features
 - 6.1 Battery Low Signal

1.0 Precautions and General Information:

All μ Max μ m® Models:

To conserve battery life the μ Max μ m® uses an automatic power down routine to turn itself off after approximately 15 minutes of non-movement of the spindle or inactivity of the push buttons or data output.

μ Max μ m® units are ruggedly built to withstand hard use, and their gasketed case, crystal and stem assemblies resist encroachment by most fluid. However, μ Max μ m® units should never be immersed. Regularly inspect all seals to guard against fluid penetration.

NOTE: To prevent contaminate from entering the 7-pin digital output connector, the output cover should always be firmly in place whenever an output cable is not connected.

2.0 Product Features

Rotating Bezel - Allows rotation through 270° for ease of reading.

Controls - Makes use of three push buttons(inch/mm, M/OFF, ZERO/ON).

inch/mm -Allows the selection of inch or metric display any time a reading is present.

M/OFF -Used to turn the unit "off" and for entering setup Modes. The M/OFF button must be held down for a minimum of 2 seconds to turn the unit "off".

ZERO/ON - This button is used to turn the unit "on". When the unit is "on" the button is used to electronically set the analog display to its mid point and set the digital display to zero or a preset value(if used).

The button can also be used to place the unit into a mode which indicates the true zero position of the spindle. To enter this True Spindle Position mode, first make sure that the unit is on-scale, then press and hold ZERO/ON for 1+ second. Once the mode is selected, the unit displays the actual position of the spindle in the Indicators measuring range and the Indicators analog display changes to the single element mode showing the position of the spindle to its range. To zero the gage, press and release ZERO/ON.

Preset Value (Mode M2) -Allows the entry of any value in the range of ± 99.99995 in. (± 999.999 mm) as a preset or actual number.

Switchable Inch Resolution (Mode M2) - Resolution can be selected as 0.0001 in. or 0.00005 in. on standard 50in resolution models only.

Tolerance Limits (Mode M12 & M23) - Allows the entry of a pair of tolerance limit values in the range of t 0.07995in.(± 1.999mm).

GO/NOGO -Allows tolerance evaluation by displaying GO/NOGO tolerance symbols in both inch or metric.

Analog Magnification (Mode M1) -Allows for a scale selection of 10%{no icon} or 50%(in.)/40%(mm){X1 icon} of digital range.

Range Signal -Notifies an "off-scale" condition when the digital range is exceeded. The digital display will turn off and the analog left or right arrow will be left on.

POWER MANAGEMENT-The μ Max μ m is designed with an auto power down feature. If it senses 15 minutes of inactivity (i.e. no spindle movement, no buttons pushed, and no data output requests), the unit will turn itself off.

Calibration Lockout (Option) -Allows the entry into the Calibration mode via a key (EKY-1024) plugged into the digital output. Calibration is inaccessible without this Access Key. Specific model's only.

3.0 Inspection

The μ Max μ m Indicator is shipped with its batteries in place. The unit will arrive in a power off condition. Turn the unit on by simply pressing the ZERO/ON button.

4.0 Mounting the Gage for Setup

A μ Max μ m indicator is normally stem mounted, but can be mounted in a gage or fixture using an optionally available back or adaptor.

- 1) If the unit is "Off" press the ZERO/ON button to turn the unit "ON".
- 2) Mount the indicator in the gage.
- 3) Place the master in the gage.
- 4) Press and hold down the ZERO/ON button for 1+ second to place the unit in the True Spindle Position mode.
- 5) Mechanically adjust the gage until the reading is at or near the desired value/or spindle position.
- 6) Securely lock the Indicator in position,
- 7) Press and release the ZERO/ON to enter "zero" setting.

5.0 Setup Modes

Entering the setup modes is accomplished by pressing and holding M/OFF. Then press and release in/mm until the desired Mx icon is displayed in the lower left corner of the LCD display.*

The gMaxpm has five setup modes identified by M1, M2, M12, M23, and M3 icons. These ICONs are located on the lower part of the display to identify the selected setup mode.

M1	signifies Measurement Direction / Analog Scale Magnification
M2	signifies Preset Entry Mode
M12	signifies Limit #1 Tolerance Entry Mode
M23	signifies Limit #2 Tolerance Entry Mode
M3	signifies Calibration Mode

***NOTE:** It is recommended that the unit be on-scale prior to performing the following operations. Whenever the Measurement Direction is changed (pressing the ZERO/OON button) in the setup mode the unit will automatically switch to the True Spindle Position Mode. The unit will have to be re-zeroed after leaving the Setup Mode function in order to return to the Gaging Mode of operation.

5.1 Changing Measurement Direction (M1)

- 1) Press and hold M/OFF(1) - then press and release inch/mm(2) until the M1 icon is displayed. (Fig.5-1a)

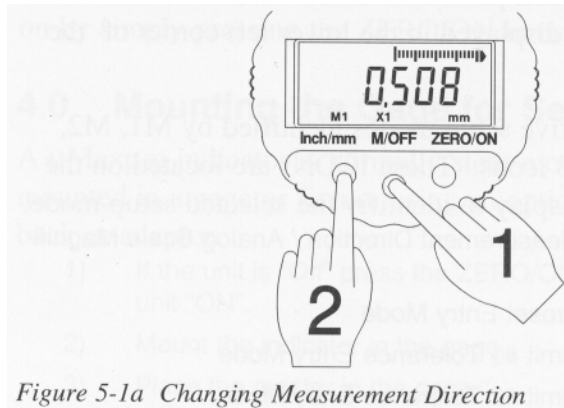

Figure 5-1a Changing Measurement Direction

- 2) Press and release ZERO/ON to select the desired Measurement Direction signified by the "R" icon for reverse mode and no icon for the normal mode. (Fig.5-1b)

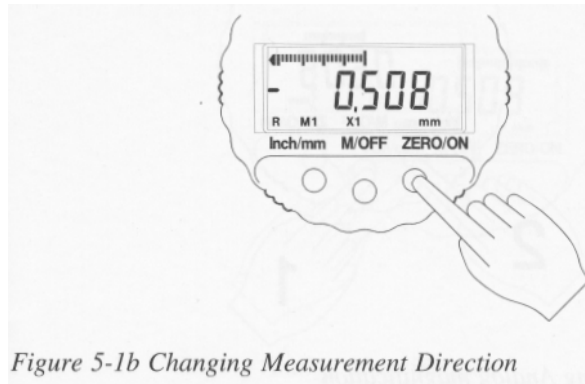

Figure 5-1b Changing Measurement Direction

- 3) Press and release M/OFF until it returns to the gaging mode(no M icon is displayed).*

5.2 Changing Analog Magnification (M1)

- 1) Press and hold M/OFF(1) - then press and release inch/mm(2) until the M1 icon is displayed. (Fig. 5-2a)

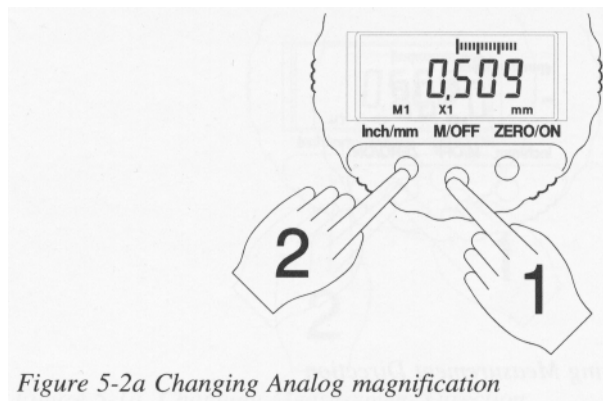

Figure 5-2a Changing Analog magnification

- 2) Press and release inch/mm to select the desired Analog Magnification signified by the "X1" icon for 50%(in.)/
40%(mm) Magnification or no icon for 10% magnification. (Fig.5-2b)

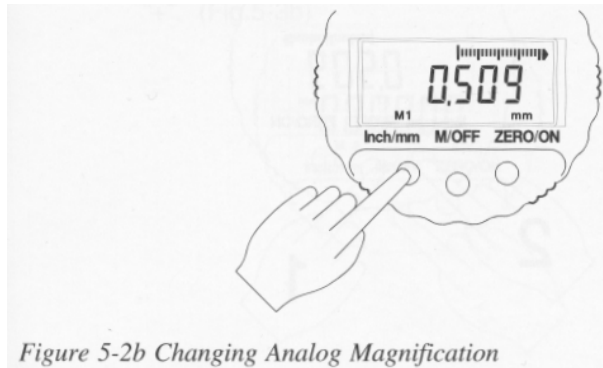

Figure 5-2b Changing Analog Magnification

- 3) Press and release M/OFF until it returns to the gaging mode(no M icon is displayed).*

Listed below are the two analog display ranges for the bar graph scale.

<u>Icon</u>	<u>± Full Scale</u>	<u>Graduation Value</u>
no icon	0.004in./0.1mm	0.0002in./0.005mm
X 1	0.02in./0.40mm	0.001 in./0.020mm

5.3 Entering Preset (M2)

- 1) Press and hold M/OFF(1) - then depress and release inch/mm(2) until the M1 icon is displayed. (Fig.5-3a).

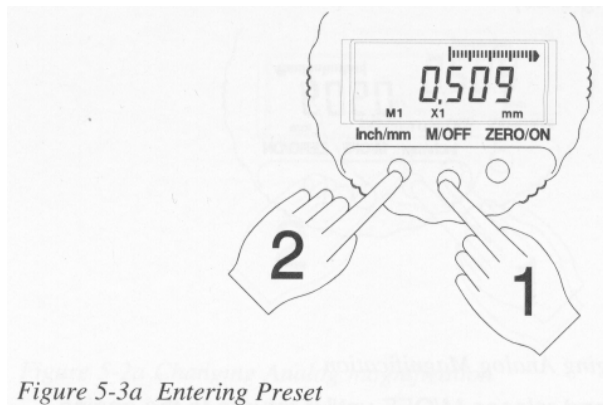

Figure 5-3a Entering Preset

- 2) Press and release M/OFF to display the M2 icon signifying the unit is in the preset entry mode. A cursor will be above the left most digital position. The left most digital position is for the sign and toggles between "-" and blank "+". (Fig.5-3b)

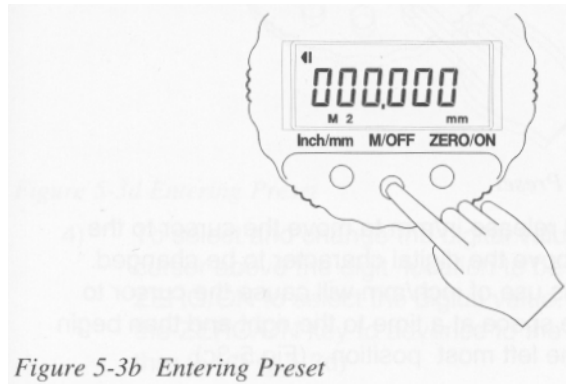

Figure 5-3b Entering Preset

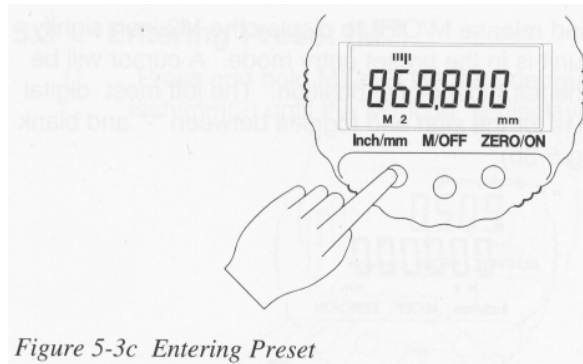

Figure 5-3c Entering Preset

- 3) Press and release in/mm to move the cursor to the position above the digital character to be changed. Continuous use of inch/mm will cause the cursor to move one space at a time to the right and then begin again at the left most position. (Fig.5-3c)

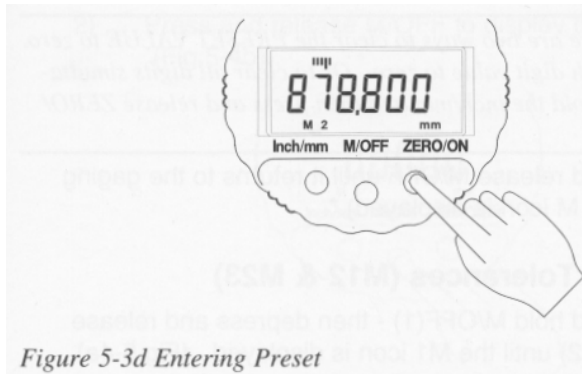

Figure 5-3d Entering Preset

- 4) To select and change the digital value, position the cursor above the digit location to be changed. Press the ZERO/ON to select the digital value. Press and release the ZERO/ON key to advance to the available digits of 0 thru 9. (Fig.5-3d)
 - A. Continuous use of this key will cause the digits to repeat.
 - B. In the most right position of the inch mode the only values available are 0, 5, or blank.^
- ^ **High Resolution Models can have 0, 2, 4, 6, or 8 in inch mode and 0, or 0.5um in metric mode.**

NOTE: There are two ways to clear the PRESET VALUE to zero. One way is to set each digit value to zero. Or to clear all digits simultaneously, press and hold the inch/mm and then press and release ZERO/ ON.

- 5) Press and release M/OFF until it returns to the gaging mode(no M icon is displayed).*

5.4 Entering Tolerances (M12 & 23)

- 1) Press and hold M/OFF(1) - then depress and release inch/mm(2) until the M1 icon is displayed. (Fig.5-4a)

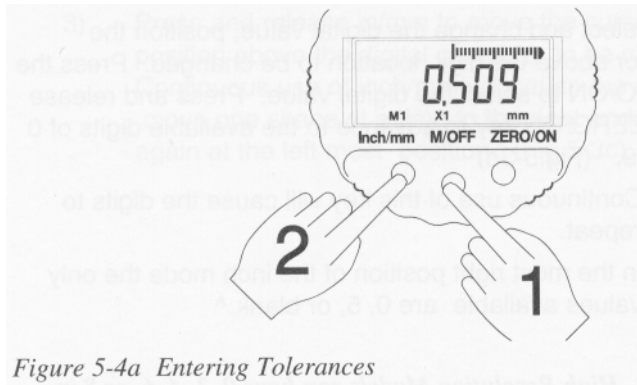

Figure 5-4a Entering Tolerances

- 2) Press and release M/OFF to display the M2 icon. (Fig.5-4b)

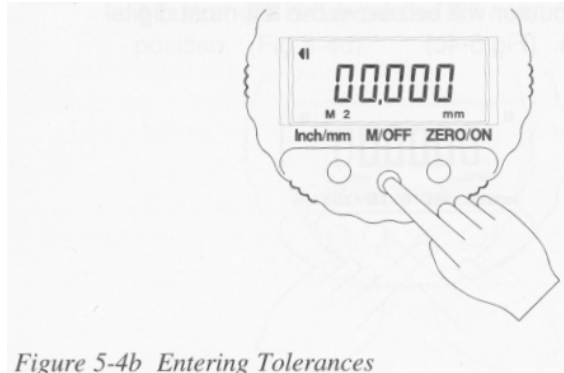

Figure 5-4b Entering Tolerances

- 3) Press and release M/OFF to display the M12 icon signifying that the unit is in the limit #1 tolerance entry mode. A cursor will be above the left most digital position. (Fig.5-4c)

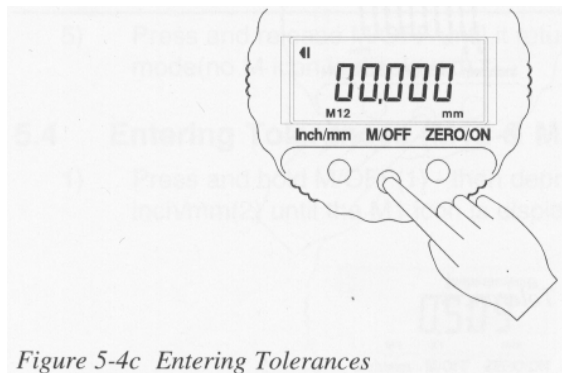

Figure 5-4c Entering Tolerances

- 4) Follow the same procedure as the Preset Mode in section 5.3 for entering the tolerance value.

- 5) Press and release M/OFF to display the M23 icon signifying the unit is in the limit #2 tolerance entry mode. A cursor will be above the left most digital position. (Fig.5-4d)

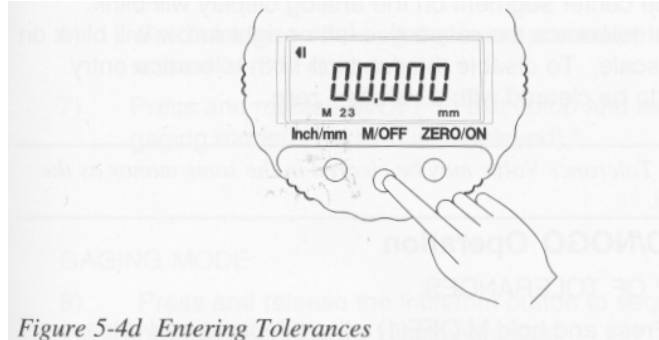

Figure 5-4d Entering Tolerances

- 6) Again, follow the procedure as outlined above for entering tolerance values(Section 5.3).
- 7) Press and release M/OFF to exit setup and return to the gaging mode(no M icon is displayed).*

NOTE: To disable the tolerance feature both tolerance entry values must be zero.

The tolerance entry limits are entered in the setup mode. To enable the tolerance function a value other than zero has to be entered into either of the tolerance entry fields(M12 & M23). When the tolerance function is enabled and the indicator has been "zeroed", the center segment on the analog display will blink. When out of tolerance the respective left or right arrow will blink on the analog scale. To disable this function both tolerance entry fields have to be cleared with a value of zero.

NOTE: The Tolerance Value may be cleared in the same manor as the Preset Value.

5.5. GO/NOGO Operation

SETUP OF TOLERANCES:

- 1) Press and hold M/OFF(1) - then depress and release inch/mm(2) until the M1 icon is displayed. (Fig.5-4a)
- 2) As described in section 5.4(3) press and release M/OFF until the M12 icon appears signifying that the unit is in the limit #1 tolerance entry mode. (Fig.5-4c)
- 3) Position the cursor by pressing and releasing the inch/mm button, moving the cursor to a position above the digital character to be changed.
- 4) Change the selected digital character by pressing and

releasing ZERO/ON.

- 5) To enter the second tolerance (limit #2), press and release M/OFF until the M23 icon is displayed. (Fig.5 4d)
- 6) Set Tolerance #2 using the same procedure as described in (3 & 4) above.
- 7) Press and release M/OFF to exit setup and return to the gaging mode(no M icon is displayed).*

GAGING MODE:

- 8) Press and release the inch/mm button to sequence through the following display choices;
 - Numerical display (in.)
 - GO/NOGO display (in.)
 - Numerical display (mm)

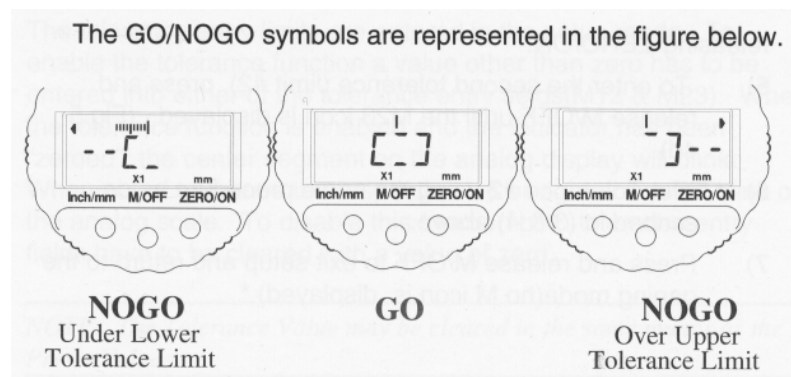

5.6 Calibration Mode (M3)

To enter Calibration Mode from the Gaging/Measurement Mode:

- 1) Fit the indicator into a calibration device so that it is "on-scale". The indicator should remain "on-scale" through-out calibration.
- 2) Select the inch or metric measuring mode.

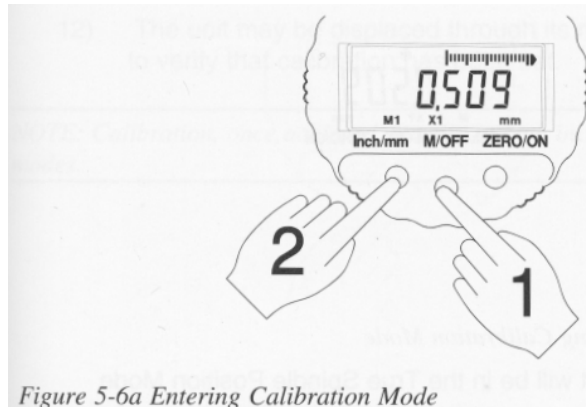

Figure 5-6a Entering Calibration Mode

- 3) Press and hold M/OFF(1) and then press and release in/mm(2) until the M1 icon is displayed. (Fig.5-6a)
- 4) Press and release M/OFF to enter M2, Preset Mode.
- 5) Again, press and release M/OFF to enter M12, Limit #1 Tolerance Entry Mode.
- 6) Again, press and release M/OFF to enter M23, Limit #2 Tolerance Entry Mode.
- 7) Press and hold M/OFF for 2+ seconds until M3 is displayed. (Fig.5-6b)

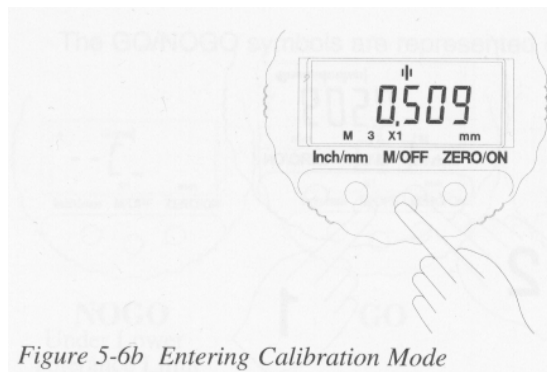

Figure 5-6b Entering Calibration Mode

- 8) The unit will be in the True Spindle Position Mode
- 9) Mechanically position the unit to zero and lock into place.
- 10) Displace the contact +0.02000in. for inch mode or 0.500mm for metric calibration.
- 11) If the display does not show +0.02000in.(+0.500mm), press and release inch/mm to make the digits count down to the number desired, or use ZERO/ON to make the digits count up. Once +0.02000in.(+0.500mm) is displayed, press and release M/OFF to complete the calibration operation and return to the gaging mode (no M icon is displayed).*

- 12) The unit may be displaced through its measuring range to verify that calibration has been set.

NOTE: Calibration, once achieved, is valid in both inch and metric modes.

6.0 Operational Features

6.1 Battery Low Signal

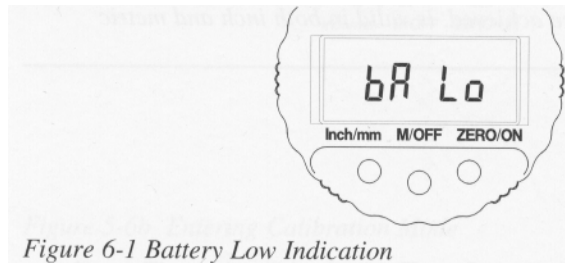

Figure 6-1 Battery Low Indication

When the Message "bA Lo" is displayed on the digital display it indicates that the battery power is too low for dependable readings and the indicator will no longer operate. Replace batteries to resume use of the indicator.

6.2 Changing the Battery

The μ Max μ m incorporates a battery tray which hold the batteries in position.

To change the battery:

- 1) Using a small screw driver (Ref: fig 6-2a) carefully slide the blade into the opening and release the battery holder from its locked position.

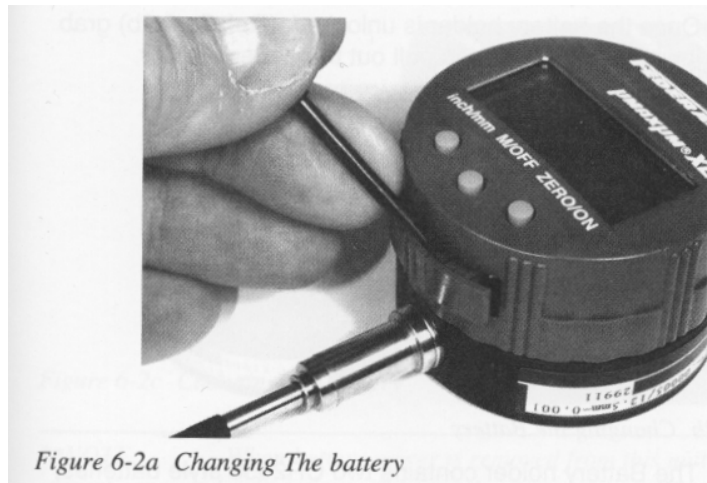

Figure 6-2a Changing The battery

- 2) Once the battery holder is unlocked, (Ref: fig 6-2b) grab it with your fingers and pull out the battery holder.

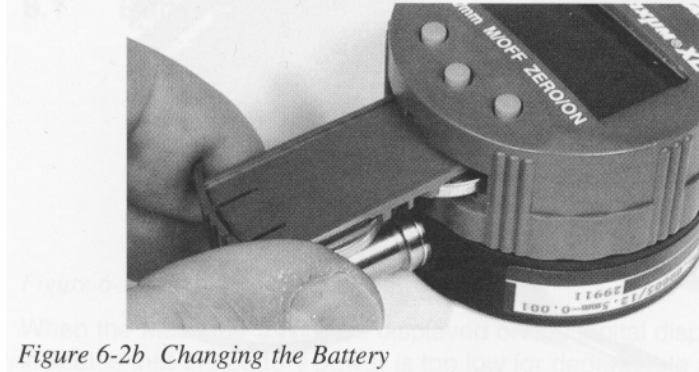

Figure 6-2b Changing the Battery

- 3) The Battery holder contains two CR2450 style batteries, Federal Part number EBY-1018. Remove the two expired batteries and replace with new ones with the large diameters into the holder.
- 4) Place the battery holder in the battery compartment and slide it in until it locks into position. (Ref: fig 6-2c)



Figure 6-2c Changing the Battery

****NOTE:** When battery power is removed from this unit the current setup and calibration will be retained in memory. When battery power is re-enabled this setup and calibration is what will be operating. Setup does not include operable functions such as “zeroing”.

6.3 Data Output

Data output is available in two standard formats and is selected through jumper connections in the mating connector. The ASCII format is an encoded 2400 Baud digital asynchronous data stream consisting of 15 characters. The BCD format is a clocked serial data stream consisting of 13 digits totaling 52 bits. For complete data output(ASCII and BCD) specifications ask for publication # A-274 Revision A

PIN NO.	SIGNAL NAME	IN/OUT I/O	SIGNAL DESCRIPTION
1	N.C.	-	No Connection
2	N.C.	-	No Connection
3	GND	-	Signal Ground
4	SREQ\	I	Request for Data Transmission
5	SMOD	I	Data Transmission Protocol No Data Connection=BCD Gnd = ASCII
6	SDAT	O	Data Output
7	SCLK	O	Clock Output

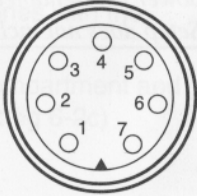

Figure 6-3 Pinout ECN-1720

7.0 Spindle Maintenance

[Reference Drawing in Section 8.1]

If the measuring spindle does not move freely, it may require cleaning. For parts refer to Section 8.1.

- 1) Unscrew the contact point (A). Use soft jaw pliers, or protect the contact point with a soft cloth.
- 2) Carefully remove the boot(B) on the units having 1.5" stem length.
- 3) Using a 9/32" or adjustable wrench, unscrew the threaded bushing (C) from the end of the stem. Be careful not to lose the spring(J) inside the stem.

CAUTION: The black ferrite Core (H) is fragile. Handle with care. Do not remove the core from the end of the Spindle unless it is damaged and requires replacement.

- 4) Carefully remove retaining ring(E)and spacer(G) from spindle(F) on the units having 1.5" stem length.
- 5) Clean all metal parts and flush out spindle cavity with a suitable solvent.
- 6) Clean the boot(B) if applicable and "O" ring (D) separately, using a suitable cleaning agent. If either is worn or damaged, replace them.
- 7) When the components are clean and dry, reassemble the spindle to the Indicator. Use new Retaining Ring (E), do not reuse the old one.

DO NOT LUBRICATE THE SPINDLE ASSEMBLY

NOTE: The spindle should be cleaned at least once a year or when normal calibration certification is performed. Spindle should be cleaned if it appears to be "sticking" or gage is not repeating proper values.

8.0 Parts and service

μMaxum Indicator parts and service are available from Federal Products Co., Providence RI USA. Contact your Federal Products representative or Federal's Gaging Products Group, in Providence,

Carefully pack items to prevent damage in shipment.

Include a brief description of the problem and the name, address and telephone number of the person to contact if we have any questions.

Send correspondence to:

Federal Products Co.
Gaging Product Group
1139 Eddy St., PO Box 9400
Providence RI 02940-9400 USA
Repair Department

For expedited warranty service,
contact our Customer Service Department
at 1-401-784-3100
and obtain a Return Authorization number.

8.1 Replacement Parts

Batteries:

EBY-1018 Lithium coin cell, commercial part number CR2450.

Lithium Coin Cells available through:

SONY Duracell
 Sanyo Fuji
 Varta Eveready(UCAR)
 Radio Shack

Contact Points:

PT-223 For .375in. dia. stem, 0.25in. long, radiused tip, 4-48 thread
 EPT-1037-W1 For 8mm dia. stem, 6mm long, radiused tip, M2,5 mm thread

Spindle Parts:

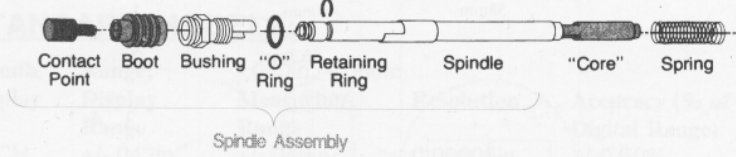

		EDI-XX10X	EDI-XX20X	EDI-XX30X	EDI-XX40X
A	Contact Point	PT-233	PT-223	EPT-1037-W1	EPT-1037-W1
B	Boot	NONE	EGU-1022	NONE	EGU-1022
C	Bushing	EBU-1473	EBU-1478	EBU-1473	EBU-1478
D	O-RING	ERG-1042	ERG-1042	ERG-1042	ERG-1042
E	Retaining Ring	NONE	ERG-1049	NONE	ERG-1049
F	Spindle	EAS-2941	EAS-2943	EAS-2942	EAS-2944
G	Spacer	NONE	EBU-1477-W1	NONE	EBU-1477-W1
H	Core Assem.	EAS-2884	EAS-2884	EAS-2884	EAS-2884
J	Spring	ESP-1112	ESP-1112	ESP-1112	ESP-1112
K	Spindle Assen	EAS-3045	EAS-3046		

Accessories: (Sold Separately)

ECV-1307-W2 Indicator Splash Cover (not included)
 ECN-1720 Output Mating Connector (not included)

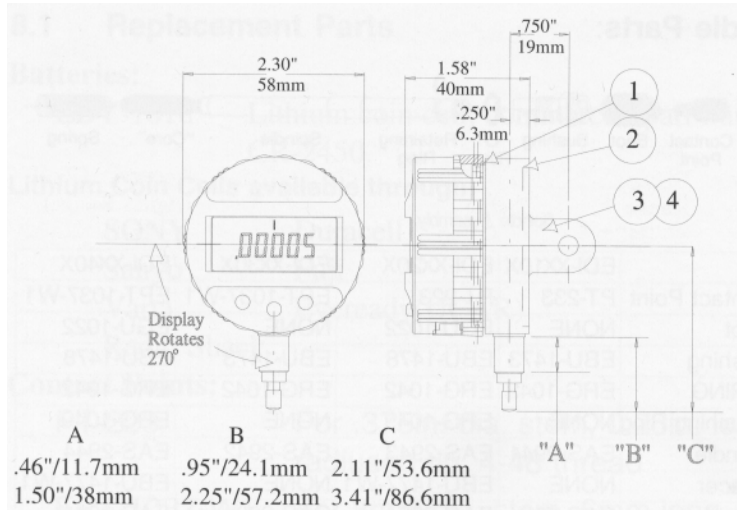

- | | |
|-------------|--|
| 1. ERG-1073 | O-Ring for Case and Bezel |
| 2. ERG-1086 | O-Ring for Case and Back |
| 3. EBK-1011 | Std. Flat Back (Other backs available-see product catalog) |
| 4. SW-329 | 2-64, Screw for Back Mounting |
| - ECS-1214 | Output Cover (Not Shown) |

9.0 Specifications

STANDARD MODELS:

Spindle	Range:	-.050in./+.060in.		
Display	Display Range	Measuring Range	Resolution	Accuracy (% of Digital Range)
INCH	+/- .042in.	+/- .040in.**	0.00005in.	+/-0.50%
		+/- .020in.	0.00005"	+/-0.25%
METRIC	+/-1.067	+/-1.000mm**	0.001 mm	+/-0.50%
		+/- .500mm	0.001 mm	+/-0.25%

HIGH RESOLUTION MODELS:

INCH	+/- .042in.	+/- .040"***	0.00002in.	+/-0.50%
		+/- .020"	0.00002in.	+/-0.25%
METRIC	+/-1.067mm	+/-1.000mm**	0.0005mm	+/-0.50%
		+/- .500mm	0.0005mm	+/-0.25%

**** This unit is a single range as specified by the asterisk. The accuracy specification is measured over the range chosen and is to be measured from the True Spindle Position.**

Gaging Force: 3 to 4 Oz/85 to 112 grams at center of travel
Weight: 6 oz/170 grams
Spindle Velocity: Unrestricted
Operating/Storage Temp:
 Operating: 50° to 130°F / 10° to 55°C
 Storage: -4° to 140°F / -20° to 65°C
Repeatability: ± 1 Least Significant Digit
Battery Life: 9 Months normal usage or 3000 Hours

NOTE: The accuracy given in the specifications is based on the digital indicator being mounted by its stem.



Federal Products Co. Instrumentation Group, 1144 Eddy Street, P.O. Box 9400 Phone: 401/784-3100
Esterline Technologies Providence, RI 02940 U.S.A. Fax: 401/784-3246